

PEDALIER

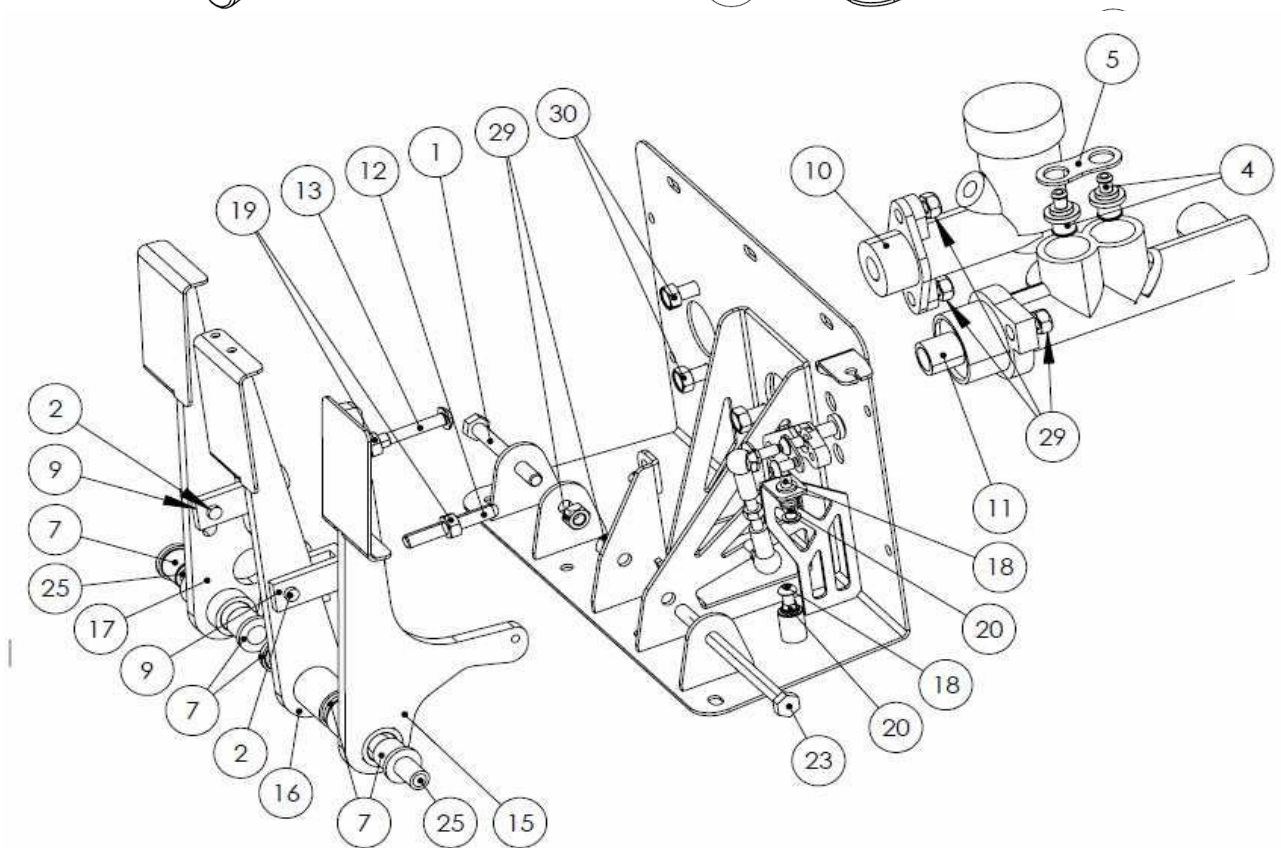
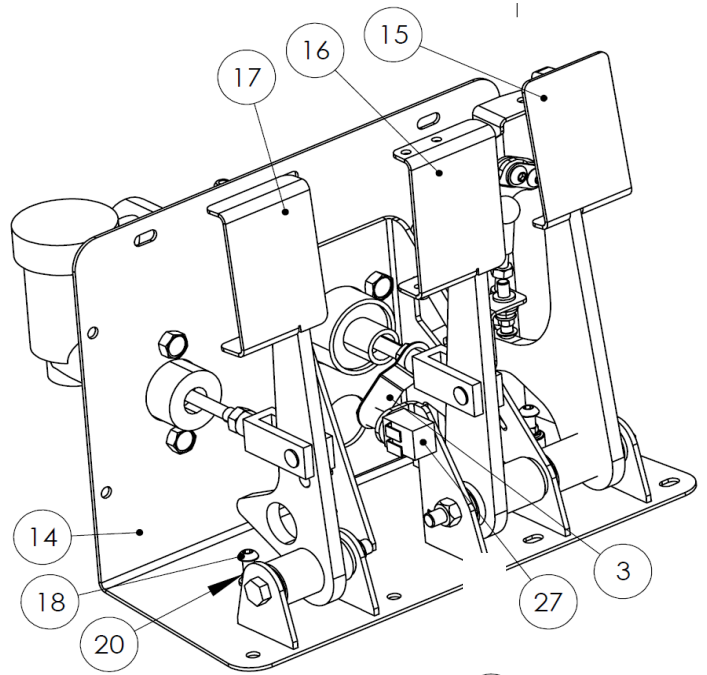
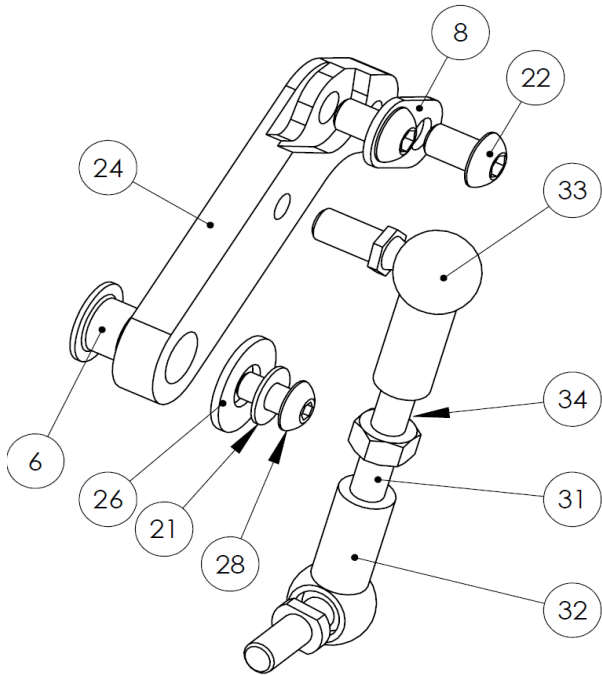

TARIFS HT

N°	REF	DESCRIPTION	DESCRIPTION	QTE
1	P216	VIS H M8x70-24 CL8.8 BICHRO	HEX HEAD SCREW M8X70-24 CL8.8	1
2	P218	AXE DE CHAPE	CLEVIS PIN	2
3	P219	REPERE DE FREINAGE	STOP LIGHT SWITCH CONTROL ARM	1
4	FR13	RACCORD EMETTEUR FREINS	FEED PIPE CONNECTOR BRAKE MASTER	2
5	FR14	PLAQUE MAINTIENT RACCORDS	FEED PIPE SECURING TAB	1
6	P221	PALIER 08-10-08	PIVOT BUSH 08-10-08	1
7	P222	PALIER 12-18-20	PIVOT BUSH 12-18-20	6
8	P234	CHAPE BRIDE PALO ACCEL	ACCELERATOR CABLE CLAMP	1
9	P11	CHAPE PEDALIER	PEDAL YOLK	2
10	CE01	MAITRE CYLINDRE EMBRAYAGE	CLUTCH MASTER CYLINDER	1
11	FR03	MAITRECYLINDRE FREIN D22.2	BRAKE MASTER CYLINDER D22.2	1
12	P235	TIGE POUSSOIR FREIN	BRAKE PUSH ROD	1
13	P236	TIGE POUSSEE EMBRAYAGE	CLUTCH PUSH ROD	1
14	P224	EMBASE PEDALIER	PEDAL BOX	1
15	P225	PEDALE D ACCELERATEUR	ACCELERATOR PEDAL	1
16	P226	PEDALE DE FREIN REH	BRAKE PEDAL REH	1
17	P227	PEDALE EMBRAYAGE	CLUTCH PEDAL	1
18	P228	VIS BHC M6x30	TRUSS HEAD SCREW M6X30	3
19	BV229	CONTRE ECROU M8 ZN	LOCKING NUT M8 ZINC	2
20	P223	ECROU M6 EMBASE	FLANGE NUT M6	3
21	P233	RONDELLE D5 PLATE ZINGUEE	ZINC WASHER D5	1
22	P231	VIS BHC M6x10	TRUSS HEAD SCREW M6X10	1
23	BV225	VIS H M8X20 CL10.9	HEX HEAD SCREW M8X20 CL10.9	1
24	P213	PALONNIER ACCELERATEUR	ACCELERATOR LINK ARM	1
25	P217	AXE DE PEDALE	PEDAL PIVOT TUBE	3
26	P232	RONDELLE D8 M ZN	WASHER D8 M ZINC	1
27	ELC06	CONTACTEUR FEUX STOP	STOP LIGHT SWITCH	1
28	P230	VIS BHC M5x10 CL10.9	TRUSS HEAD SCREW M5X10 CL10.9	1
29	BV219	ECROU M8 NYLSTOP ZINGUE	ZINC NYLOCK NUT M8	6
30	TAV258	VIS H M8x25 CL10.9	HEX HEAD SCREW M8X25 CL10.9	4
31	P239	BIELLETTE ACCELERATEUR	ACCELERATOR PEDAL LINK ROD	1
32	P211	ROTULE A 90° M6 PAS A GAUCHE	ROTARY JOINT 90° M6 LH THREAD	1
33	P212	ROTULE A 90° M6	90° BALL JOINT M6	1
34	TAR258	ECROU M6 BRUTE	M6 NUT	1